

## **Power Table Feed**

- Easy to install, no modification needed.
- Highest quality design and construction materials.
- Strengthened "ZYTEL GEAR", an extra unit to be attached free of charge (for AL-500P only).
- Safe design operation stable low noise.
- Long life span designed.



### **Power Table Feed AL-500P**

- For 2V, 3V, 5V milling machine of table Feed.
- Speed Range: 0-160 Max 160R.P.M
- Voltage: 110V 50/60Hz
- Max Torque: 780 in-lb
- Net Weight: 5.8 kg
- Gross Weight: 6.5 kg
- Packing Size: 267x176x370mm

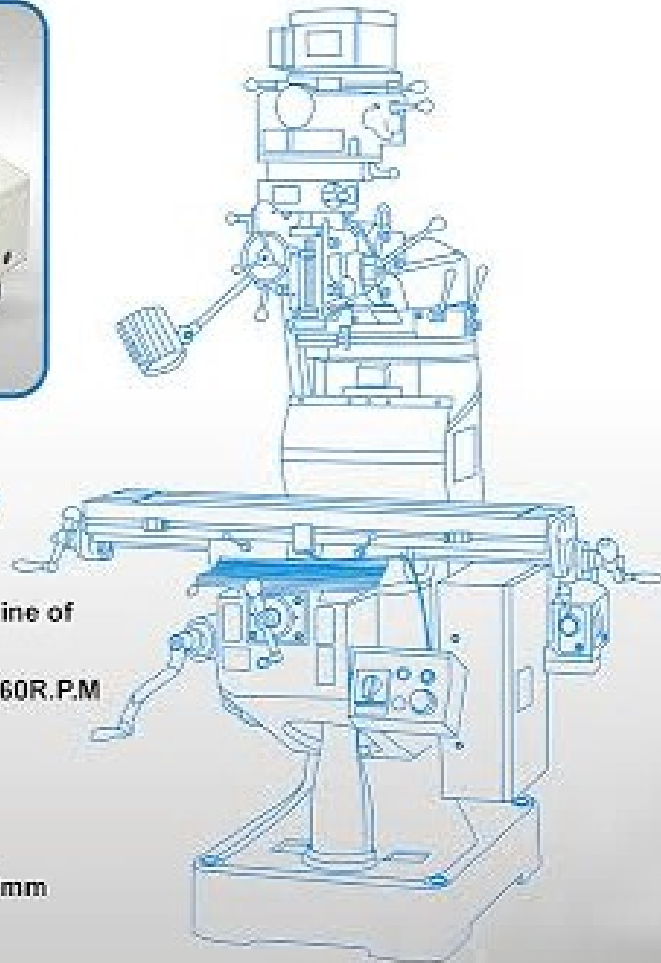

## **Power Table Feed**

Model	AL-500P
R.P.M	0~160
Max P.P.M	160
Bevel Drive Gear Rate	4.8 : 1
Max Torque	780 in-lb(900Kgf/cm)
Rated Voltage	110V 50/60Hz
Rated Current	1Amp